

4

3

2

1

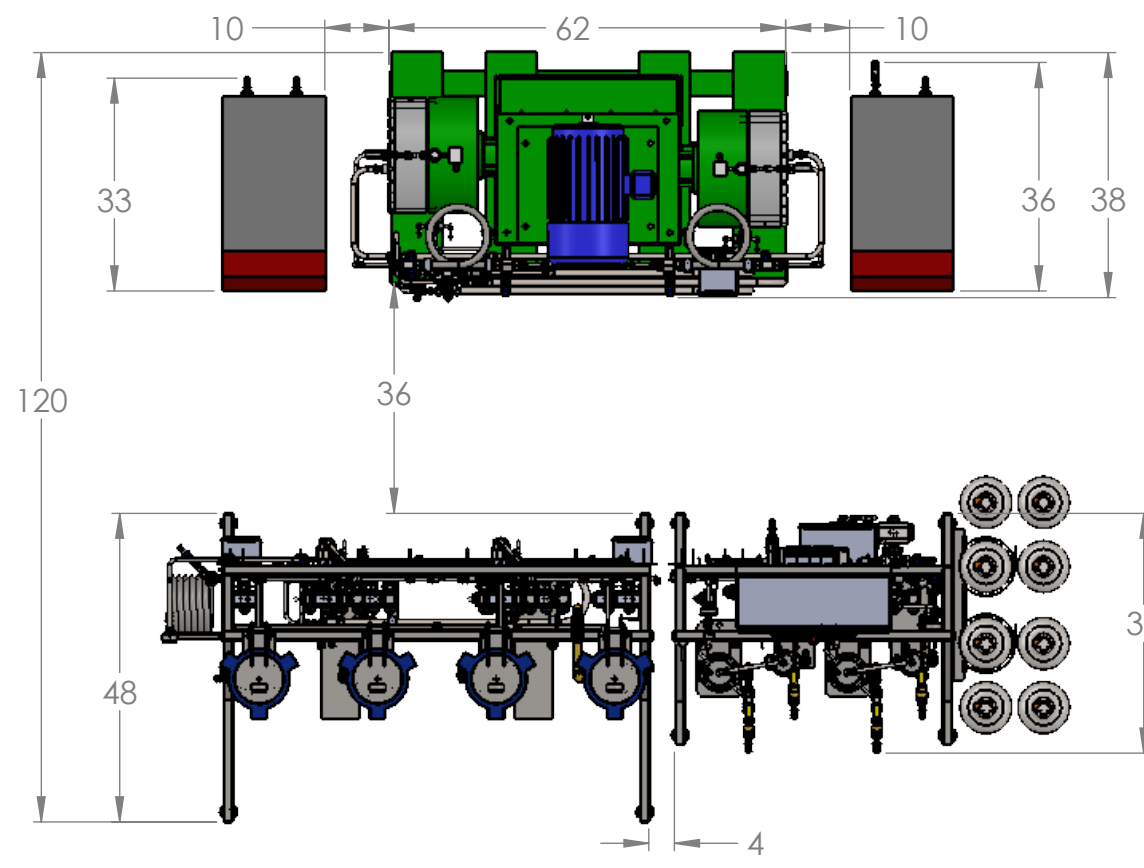

AMBIENT TEMPERATURE REQUIREMENTS:  
 ROOM - 60-80 F  
 OUTDOORS - 109-23 F (Low Ambient Available)

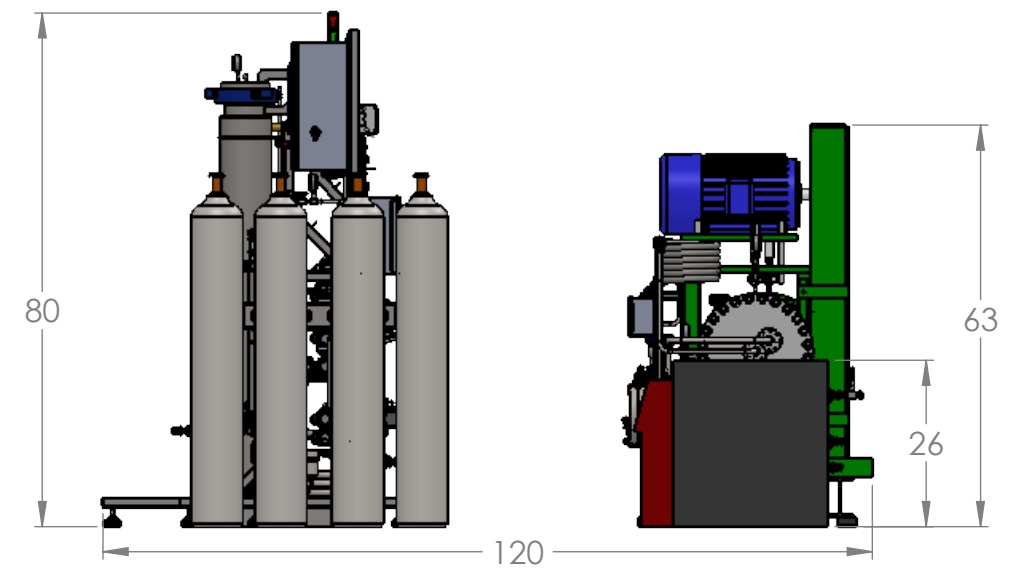
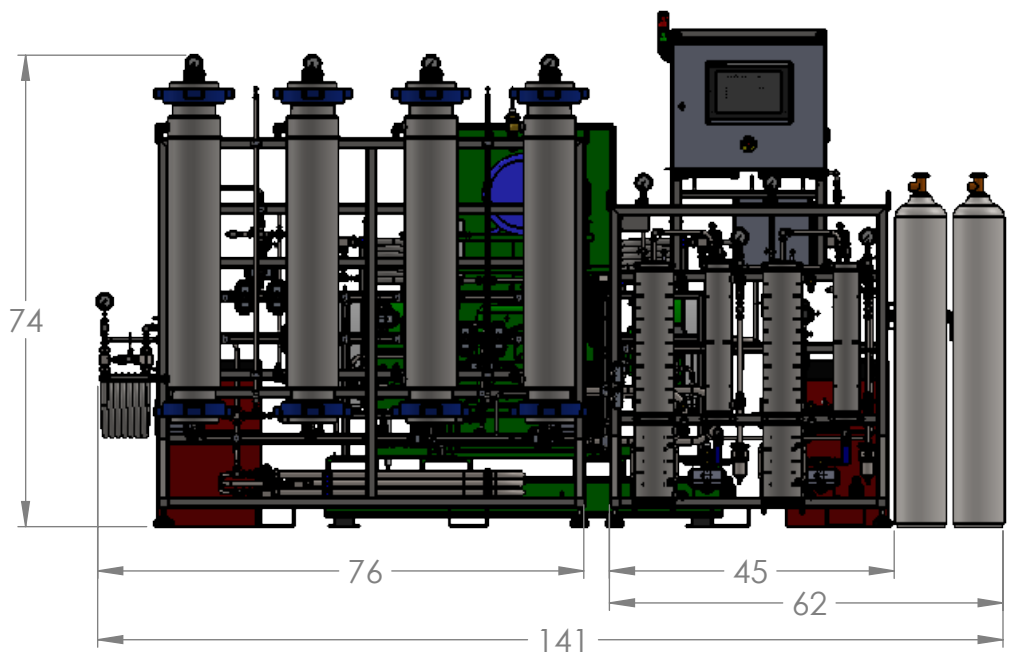
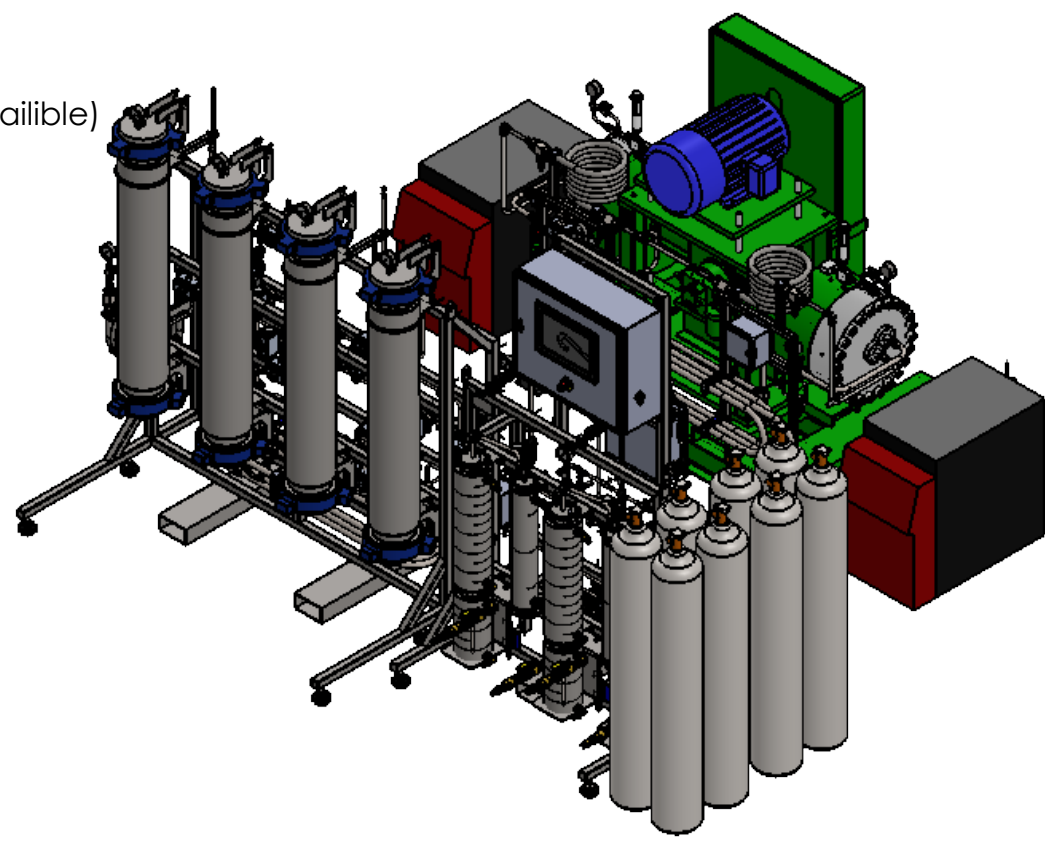

B

B

A

A

CRATE	HT	WIDTH	LENGTH	WT (LBS)
EXTRACTOR	85"	50"	80"	1300
SEPARATORS	85"	50"	72"	500
COMPRESSOR	70"	47"	83"	4600
TCU	54"	50"	48"	500

<p>31 GREENSCAPE CT, JOHNSTOWN, OH 43031 740-809-1160</p> <p><b>PROPRIETARY AND CONFIDENTIAL</b> THE INFORMATION CONTAINED IN THIS DRAWING IS THE SOLE PROPERTY OF APEKS SUPERCRITICAL. ANY REPRODUCTION IN PART OR AS A WHOLE WITHOUT THE WRITTEN PERMISSION OF APEKS SUPERCRITICAL IS PROHIBITED.</p>	UNLESS OTHERWISE SPECIFIED: DIMENSIONS ARE IN INCHES TOLERANCES: FRACTIONAL ± 1/16 ONE PLACE DECIMAL ± 0.125 TWO PLACE DECIMAL ± 0.0625 THREE PLACE DECIMAL ± 0.005	NAME	DATE	<b>APEKS SUPERCRITICAL</b> TITLE: <h1>OVERALL DIMENSIONS</h1> SIZE DWG. NO. REV <b>B</b> DU_2000-4X20L_01 <b>A</b> SCALE: 1:50 WEIGHT: SHEET 1 OF 2	
	DEBURR AND BREAK SHARP EDGES	DRAWN	TCW		9/27/19
	MATERIAL	CHECKED			
	FINISH	ENG APPR.			
DO NOT SCALE DRAWING		MFG APPR.			
		Q.A.			
		COMMENTS:			

4

3

2

1

4

3

2

1

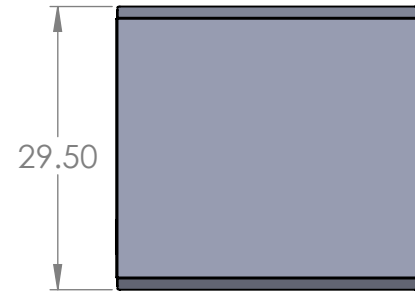

STEP-UP TRANSFORMER  
ONLY REQUIRED IF 208-230  
VOLT POWER IS AVAILABLE

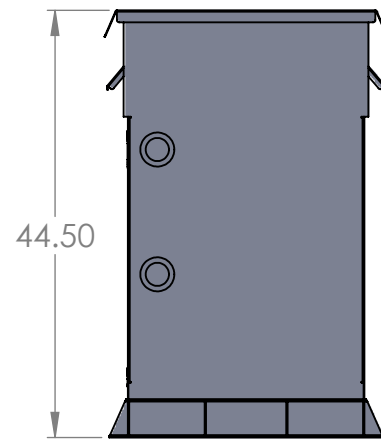

193.00 121.00

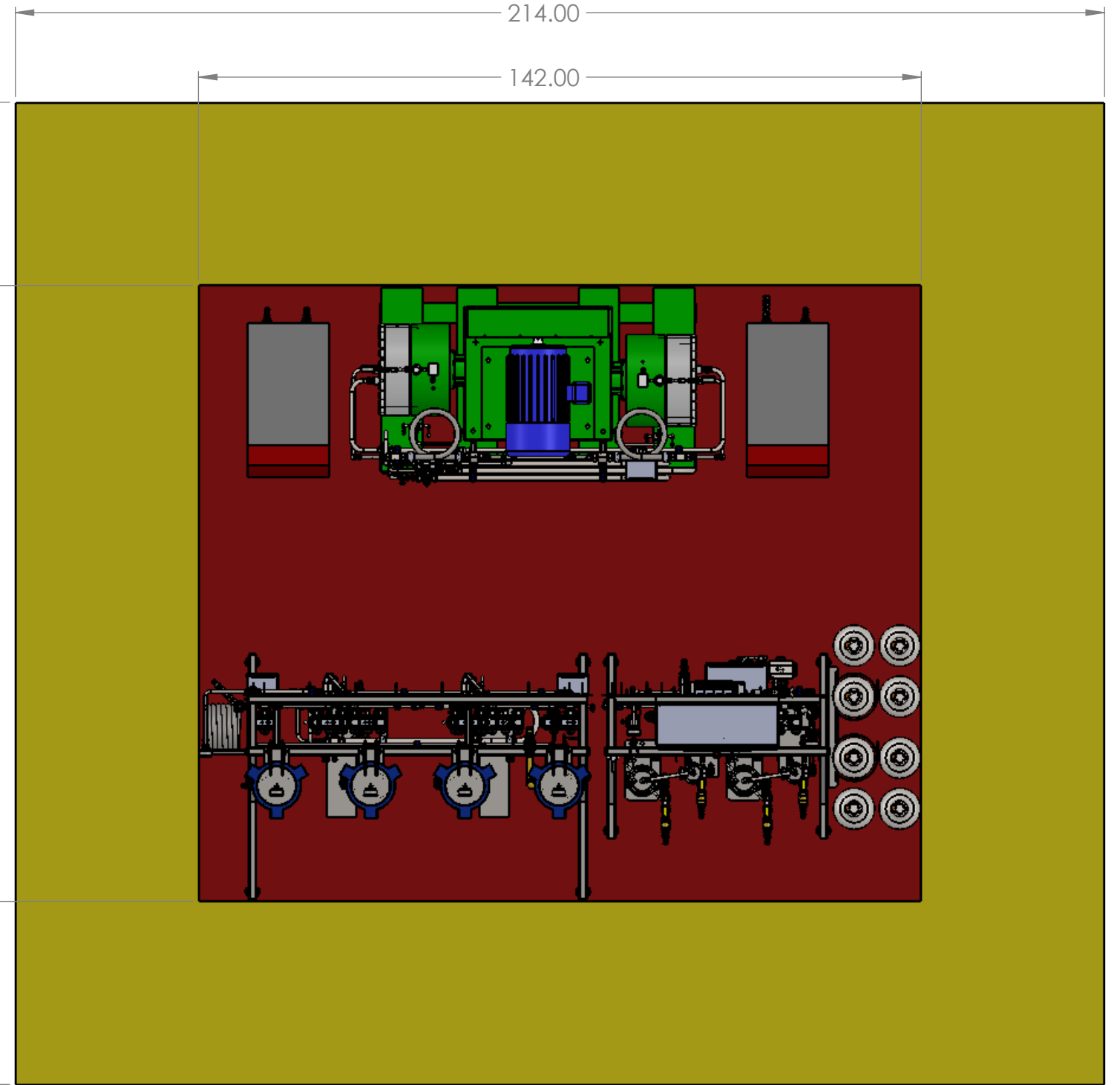

CHILLER	HT	WIDTH	LENGTH
MTA 10 TON	56.5"	30"	75"
ADVANTAGE 10 TON	80"	53.5"	70"
30 TON	100"	88"	123"

MTA 10 TON STANDARD CHILLER,  
ADVANTAGE 10 TON ALTERNATE.  
CONTACT YOUR SALES REP FOR SPECIFIC MODEL  
30 TON CHILLER UNIT IS FOR MULTIPLE  
SYSTEMS SHARING THE SAME COOLING LOOP.



31 GREENSCAPE CT,  
JOHNSTOWN, OH 43031  
740-809-1160

**PROPRIETARY AND CONFIDENTIAL**  
THE INFORMATION CONTAINED IN THIS  
DRAWING IS THE SOLE PROPERTY OF  
APEKS SUPERCRITICAL. ANY  
REPRODUCTION IN PART OR AS A WHOLE  
WITHOUT THE WRITTEN PERMISSION OF  
APEKS SUPERCRITICAL IS PROHIBITED.

UNLESS OTHERWISE SPECIFIED:

DIMENSIONS ARE IN INCHES  
TOLERANCES:  
FRACTIONAL ± 1/16  
ONE PLACE DECIMAL ± 0.125  
TWO PLACE DECIMAL ± 0.0625  
THREE PLACE DECIMAL ± 0.005

DEBURR AND  
BREAK SHAPE  
EDGES

MATERIAL

FINISH

DO NOT SCALE DRAWING

	NAME	DATE
DRAWN	TCW	9/27/19
CHECKED		
ENG APPR.		
MFG APPR.		
Q.A.		

COMMENTS:

**APEKS SUPERCRITICAL**  
TITLE:  
**FLOOR LAYOUT**

SIZE	DWG. NO.	REV
<b>B</b>	DU_2000-4X20L_01	<b>A</b>

SCALE: 1:100 WEIGHT: SHEET 2 OF 2

4

3

2

1

B

B

A

A